

PANDORA'S BOX UNDONE

*This box won't release all the evils of the world, but it will help you organize your ephemera!
Use it to store mini file folders, photos or even recipes.*

BOX DIMENSIONS:

7 ¼" W X 5" H X 2" D (18.4 cm W X 12.7 cm H X 5.1 cm D)

SUPPLIES NEEDED:

- Chipboard or mat board, cut to the following sizes:
 - o 3 pieces 7 ¼" X 2" (18.4 cm X 5.1 cm)
 - o 2 pieces 7 ¼" X 5" (18.4 cm X 12.7 cm)
- Decorative paper, cut to the following sizes:
 - o 1 piece 8 ½" X 8 ½" (21.6 cm X 21.6 cm)
 - o 1 piece 8 ½" X 11" (21.6 cm X 27.9 cm)
- Cardstock, cut to the following sizes*:
 - o 1 piece 7" X 11" (17.8 cm X 27.9 cm)
 - o 1 piece 7" X 5 ½" (17.8 cm X 14 cm)
 - o 4 pieces 7 3/8" X 4 ½" (18.7 cm X 11.4 cm)
 - o 2 pieces 6" X 4 ½" (15.2 cm X 11.4 cm)
 - o 2 cardstock mini file folders (6 ¼" X 9" open) (15.9 cm X 22.9 cm)
- Piece of scrap paper
- For box closure:
 - o 1 piece 18" (45.7 cm) ribbon, or
 - o self-adhesive magnets

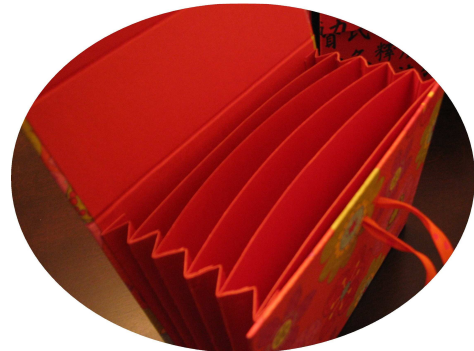

* See tip sheet on getting maximum usage from each sheet of 12" X 12" cardstock

TOOLS NEEDED:

- Bone folder
- X-acto or craft knife
- Scissors
- Pencil
- Eraser
- Ruler
- Brush (for gluing)
- Self-healing mat
- PVA glue or other strong craft glue (i.e. Aleene's Original Tacky Glue)
- 16 paper clips
- 8 mini bulldog clips, small clamps or clothespins
- Eyelet punch & small hammer (if using ribbon closure)

PANDORA'S BOX UNDONE

PREPARING THE BOX STRUCTURE -

1. Take the 8 ½" X 8 ½" (21.6 cm X 21.6 cm) piece of decorative paper, and place decorated side face down on your work surface.

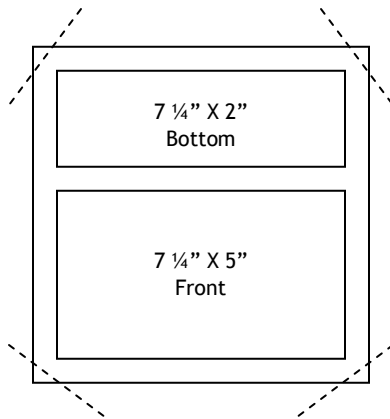

2. Lay one 7 ¼" X 2" (18.4 cm X 5.1 cm) and one 7 ¼" X 5" (18.4 cm X 12.7 cm) piece of chipboard centred horizontally on the decorative paper, leaving a margin of 1/8" (0.3 cm) between both pieces.

3. Glue chipboard in place, using a bone folder to smooth out any wrinkles or air bubbles on the paper side.

PAPERMUSE TIP:

Before starting your project, cover your work surface with wax paper to protect it from glue, and keep a damp rag handy to wipe off excess glue.

4. Cut off the corners of the paper, leaving a small space between the corner of the board and the cut (just enough to cover the edge of the chipboard).

5. With your bone folder, fold the paper over each edge of the chipboard (to help it retain its shape), then glue it in place. Use your bone folder to smooth the paper out. Set this piece aside.

6. Take the 8 ½" X 11" (21.6 cm X 27.9 cm) piece of decorative paper, and place decorated side face down.

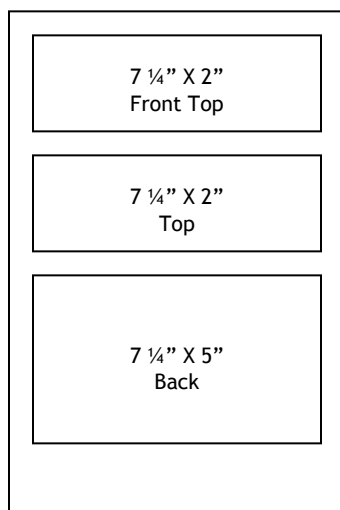

7. Lay two 7 ¼" X 2" (18.4 cm X 5.1 cm) and one 7 ¼" X 5" (18.4 cm X 12.7 cm) piece of chipboard centred horizontally on decorative paper, leaving a margin of 1/8" (0.3 cm) between each piece.

There will be about 1 ½" (3.8 cm) of extra paper at the bottom; not to worry...this is intentional.

8. Glue chipboard in place, using a bone folder to smooth out any wrinkles or air bubbles on the paper side.

9. Place the first completed section on top of the extra margin of paper, leaving a margin of 1/8" between section #1 and the chipboard; your project should now look like the diagram at right.

10. Glue the chipboard pieces and section #1 in place.

11. Cut off the top two corners of the paper (see step 4).

12. With your bone folder, fold the paper over each edge of the chipboard, then glue the paper in place. Use your bone folder to smooth the paper out.

13. Take the 7" X 11" (17.8 cm X 27.9 cm) and the 7" X 5 1/2" (17.8 cm X 14 cm) pieces of cardstock, and place them centred horizontally on the box structure. Glue cardstock pieces in place and smooth with bone folder.

14. Slide your bone folder in each of the 1/8" creases, on both sides of the box structure. This will ensure that your box folds will be neat and that it will close properly.

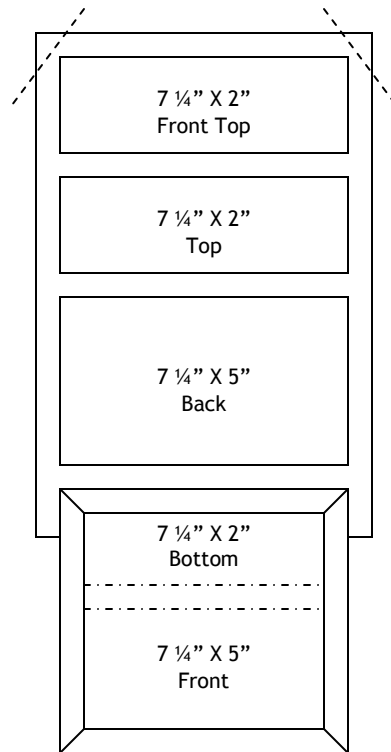

IF YOU ARE MAKING A RIBBON CLOSURE -

On the cardstock side of the Front Top Panel, make a mark in pencil at 3 1/4" (8.3 cm) and 4" (10.2 cm) from the left edge, each about 1" (2.5 cm) from the top.

Using the eyelet punch and small hammer, make holes in the two marked spots.

Close the box. Through the two newly punched holes, mark hole placement in pencil on the Front Panel. Using the eyelet punch and small hammer, make holes in the two marked spots. Your ribbon will be threaded through both panels when the box is finished.

MAKING THE DIVIDERS AND THE SIDES -

18. Take the two pieces of 6" X 4 1/2" (15.2 cm X 11.4 cm) cardstock, placing the long side horizontally (in landscape format). Starting from the left edge, score and fold the cardstock at every 1/2" (1.3 cm) mark. Repeat for the second piece of cardstock. Set aside these accordion folds.



19. Take the four pieces of 7 3/8" X 4 1/2" (18.7 cm X 11.4 cm) cardstock, placing the long side horizontally (in landscape format). Fold each piece of cardstock 3/8" (0.95 cm) from the left and the right edges. These will be the box dividers.

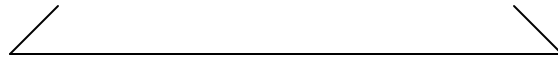

20. Unfold the above pieces of cardstock. Place glue on one of the 3/8" (0.95 cm) panels - to make gluing easier, place a piece of scrap paper on top of the cardstock, leaving only the 3/8" panel visible:



21. Place the glued panel into a valley of the first accordion-folded cardstock. Please pay attention to the exact valleys inside which the panels will be glued, and to the direction of the accordion-folded cardstock.

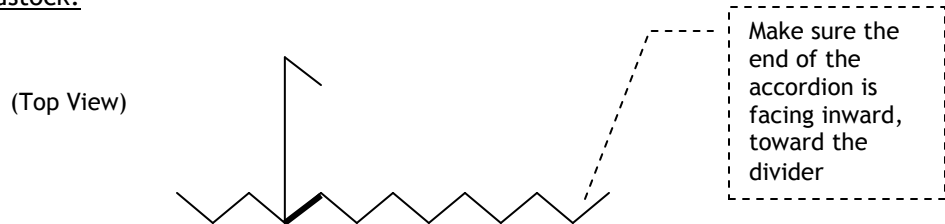

22. Glue the rest of the panels into the valleys of the first accordion-folded cardstock. It should now look like the diagram below.

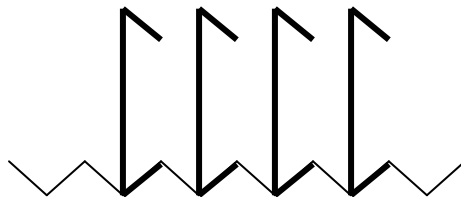

23. Place glue on each of the other 3/8" (0.95 cm) panels, and glue them to the matching valleys on the second accordion-folded cardstock. Your project should now look like this.

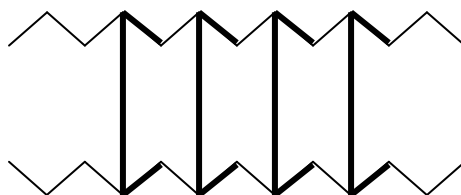

Place paperclips at the top and bottom of each of the divider panels until the glue dries (a few minutes).

24. Remove paperclips from the dividers.

25. Each of the last outside panels of the accordion-folded cardstock will be glued to the inside of the box structure.

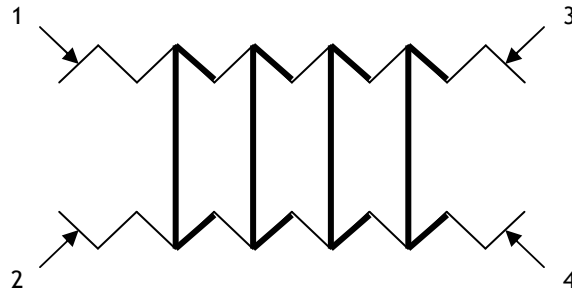

Place glue on panels 1 & 2 of the accordion fold, and glue to the Back Panel of the box structure, on the cardstock side.

26. Place glue on panels 3 & 4 of the accordion fold, and glue to the Front Panel of the box structure, on the cardstock side. In order to do this you will need to fold up the Front Panel.

27. Place bull dog clips, small clamps or clothespins on the glued panels until the glue dries (a few minutes).

Front Top

Top

Back

Bottom

Front

(Open Box Structure, Cardstock Side Facing Up)

IF YOU ARE USING A MAGNET CLOSURE -

On the cardstock side of the Front Top Panel, make a mark in pencil at the halfway mark, 3 5/8" (9.2 cm), about 1" (2.5 cm) from the top.

Connect a (+) with a (-) magnet. Remove the paper backing from one of the magnets and adhere to the spot measured above.

Remove the paper backing from the second magnet. Close the box. Press the Front Top Panel down so that the second magnet adheres to the Front Panel.

HOW TO GET MAXIMUM USAGE OF 12" X 12" CARDSTOCK FOR THIS PROJECT

cardstock #1

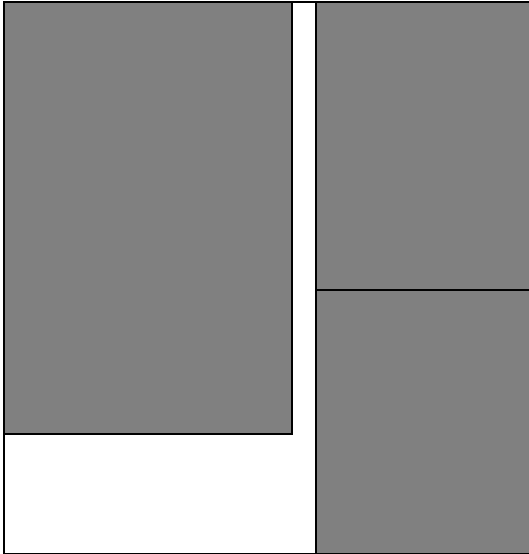

- 1 file folder (6 ¼" X 9")
- 2 accordion sides - 2 X (6" X 4 ½")

cardstock #2

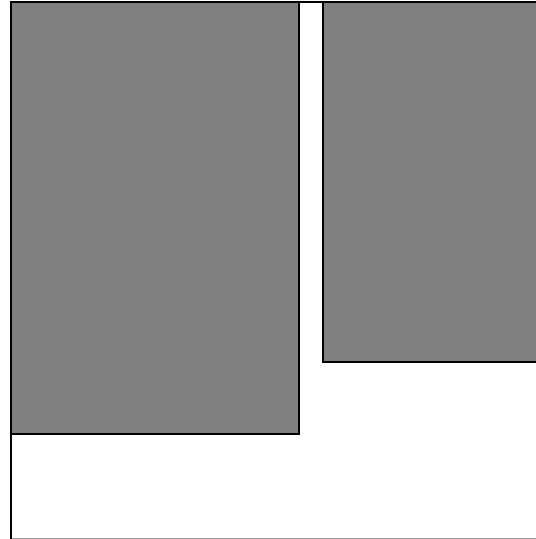

- 1 file folder (6 ¼" X 9")
- 1 piece for inside cover (7" X 5 ½")

cardstock #3

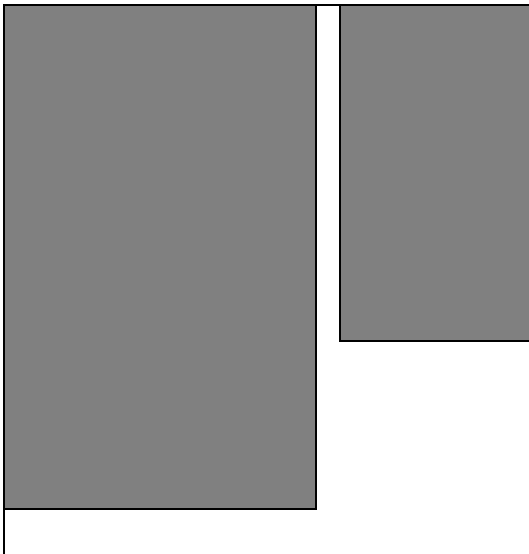

- 1 piece for inside cover (7" X 11")
- 1 divider (4 ½" X 7 3/8")

cardstock #4

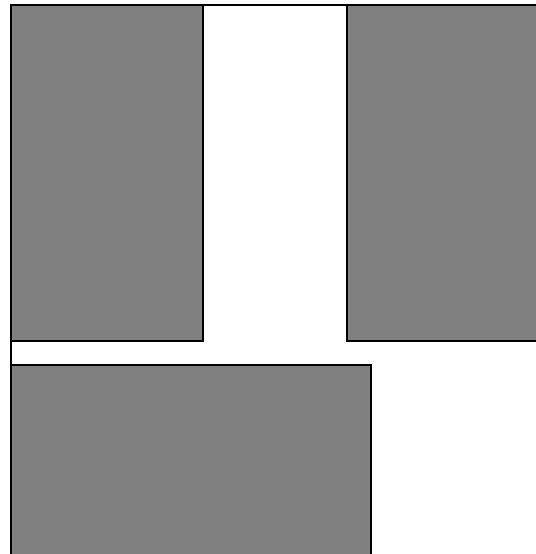

- 3 dividers - 3 X (4 ½" X 7 3/8")